

VENTILAIR INDIA



VENTILAIR INDIA

VENTILAIR - Axial Flow Fan are used for general ventilation fume exhaust and it can be as Roof Extractor & Bifurcated Fan



TYPE

- (1) Direct Drive
- (2) Belt Drive on request

APPLICATION

VENTILAIR - Axial Flow Fan are specially manufactured for all type of industrial applications as well as HVAC applications. The sizes of the fan starts from 300 mm to 1600 mm dia meter.

The performance range is from 1000 to 150000 m³/h on air volume, at static pressure up to 1500 mm WG

IMPELLER

VENTILAIR - impellers, blades and hubs are made of die cast aluminium alloy. The aerodynamical profile gives guarantee for high efficiency and optimum noise. The hub is fitted with taper bush assembly for easy fitting in fix blade & adjustable pitch

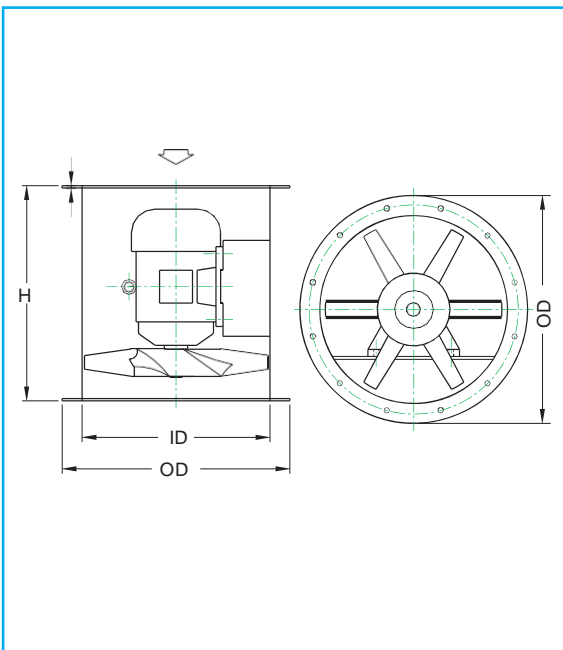

OVER ALL DIMENSIONS				
VEAP	OD	T	ID	H
300	385	5	300	350
450	485	5	300	430
500	585	6	500	350
600	685	6	600	430
700	785	6	700	440
800	885	6	800	560
900	985	6	900	575
1000	1085	6	1000	590
1200	1305	10	1200	680
1300	1405	10	1300	760
1400	1505	10	1400	760
1500	1605	10	1500	760
1600	1706	10	1600	800

VENTILAIR INDIA



DRIVE ARRANGEMENTS

- (A) Direct-Drive arrangements
- (B) Belt-Drive arrangements

Coupling drive arrangement can be provided on request.

CASING

Axial Flow Fan casing is fabricated from MS sheets & plates are fitted with Flanges on both the ends.

MOTOR

The standard A.C. motors are totally enclosed fan cooled (TEFC), squirrel cage induction type suitable for ambient temperature upto 40°C, Flame proofs motors like class H and high temperature motors can be supplied on request.

APPLICATION

AIR COOLING SYSTEM, BIFURCATED FAN, ROOF EXTRACTOR, KITCHEN EXHAUST, BASEMENT VENTILATION, TUNNEL VENTILATION, GENERAL VENTILATION, PARKING VENTILATION, FUME EXHAUST, IN LINE FAN APPLICATIONS, INDUSTRIAL EXHAUST.

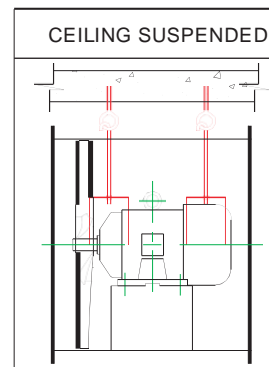
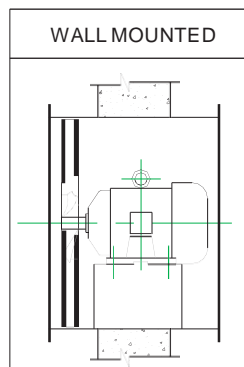
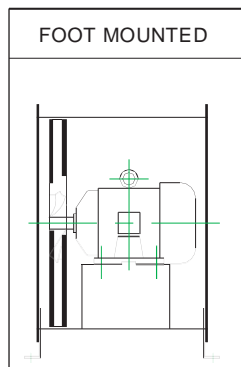

Fans are available in above mounting arrangements.

VENTILAIR INDIA

PRODUCT RANGE

- Dust Proofing
- Dust Scrubbers
- Combustion Fans
- Dust Collector
- Roof Extractor
- Paint Booths
- Bag Filters
- Axial Fans
- Centrifugal Blowers
- General Ventilation
- Fume/Dust Extractor System
- Air Cooling System

The intention of this brochure is to introduce you to, and acquaint you with the capabilities of the Ventilair organization in the offered product areas. It will not answer all your immediate questions, and indeed, it will no doubt raise others. We welcome your interest in our products and shall be very pleased to provide further information.

GUARANTEE

Ventilair guarantees its products to be free of defects in materials and workmanship for a period of one year from the date of delivery from the factory, provided motors are properly installed with overload protector. Ventilair agrees to repair or replace defective parts or part to be returned to the factory, all transportation charges prepaid. Ventilair does not guarantee against abrasion, corrosion or erosion. Ventilair shall not be held responsible for any charges in connection with the removal or replacement of alleged defective equipment nor for incidental consequential damages.

In accordance with our policy of continual improvement in design, we reserve the right to depart from the details given in this brochure.

VENTILAIR INDIA (P) LTD.

11/7, MILE STONE MATHURA ROAD, FARIDABAD - 121003, (HARYANA)

MOB. 9971026641, 9818046048

Email: salesventilair@gmail.com, Website: www.ventilairindia.com